

Description

The electronic power relay EPR10 is a solid state relay for high continuous currents. It is suitable for use in utility vehicles and special vehicles where reliability and functional safety are at a premium. At DC 24 V, the EPR10 allows a continuous load of up to 200 A.

The EPR10 is available in two different versions: EPR10-N is a relay and has no protective function. Two performance classes are available (up to 100 A and up to 200 A). EPR10-P is a protective relay and monitors both the load current and the thermal load. In the event of a critical condition, the device will automatically interrupt the circuit and will issue a group fault signal.

Note: We are preparing a separate version for applications where the current can flow in both directions. The present EPR10 design only allows one current direction.

US patent number: US 10,021,788 B2
US 10,070,514 B2

Applications

Powerful loads in DC 12 V and DC 24 V on-board electrical systems, which have to be supplied continuously with currents from 75 A to 200 A and which have to be switched frequently:

- Pumps
- Ventilations
- Cooling systems

Benefits

- 80 % less space requirement than similar conventional solid state relays:
 - no heat sink required
 - low internal resistance through parallel connection of power semi-conductors
 - technically mature heat management
 - cooling through connecting cables
- Low investment costs:
 - blade fuses in sub-paths and heat sinks superfluous because the EPR protects against overcurrent and short circuit
- Minimised maintenance costs:
 - enhanced availability due to a much longer life span compared to mechanical relays
 - very high resistance against dust, humidity, vibration and shock due to the sealed electronic circuitry
- Less CO₂ emission:
 - due to low internal resistance
 - due to minor holding power
- Flexible design:
 - the device switches without a sound and can therefore be installed in the passenger cabin without being noticed.



EPR10

Technical data (25 °C)

Load circuit

System voltage	12 V DC / 24 V DC
Max. continuous current	EPR10-N (relay version without protective function) 100 A or 200 A (please also see derating information)
Current rating range	EPR10-P (with protective function) 75 A, 100 A, 125 A, 150 A, 175 A, 200 A
Max. overvoltage	36 V DC

Max. switch-off current	Resistive loads (L/R < 0,3 ms)	Inductive loads Last (L/R < 2 ms)
EPR10-N - 100 A	700 A	100 A
EPR10-N - 200 A	1400 A	200 A
EPR10-P - 75 A	375 A	75 A
EPR10-P - 100 A	500 A	100 A
EPR10-P - 125 A	625 A	125 A
EPR10-P - 150 A	750 A	150 A
EPR10-P - 175 A	875 A	175 A
EPR10-P - 200 A	1000 A	200 A

Voltage drop	85 mV
Max. switching frequency	1 Hz
Reverse polarity protection	without Note: Observation of correct polarity when connecting the device is imperative to avoid damage of the relay.
Load output	HSS
Leakage current	< 10 µA

Control circuit

Connector	Tyco HDSCS 3-pole part number 1-1418448-1 Pin assignment: 1 = GND (chassis) 2 = SF (output group fault) 3 = IN (control input)
Control voltage	ON 6 ... 32 V DC OFF: 0 ... 3 V DC
Max. overvoltage	36 V DC
Control current	at 12 V DC 2.5 mA at 24 V DC 4 mA at < 3 V DC < 10 µA
Rising edge	< 5 ms

Technical data (25 °C)

Signal outputs

Reverse polarity protection	without
Switch type	“low side switch”
Voltage	0 ... 32 V DC
Max. leakage current	20 µA
Max. load current	2 A

General

Typical life	> 1,000,000 cycles
Trip current	only EPR10-P (with protective function) 1.3 times rated current ± 15 %
Trip time	only EPR10-P (with protective function) selectable between 0.2 / 0.5 / 0.7 s ± 15 %
Excess temperature	only EPR10-P (with protective function); circuit will be disconnected with excess temperature; (reset after 500 ms OFF condition)
Temperature range	-40...+85 °C in operation -55...+90 °C for storage
Degree of protection	IP57
Vibration	> 6 g
Chemical resistance	oil, grease, alcohol, urea, extinguishing agents, battery acid, salt mist, detergents, humidity

Enclosure and mounting

Material of enclosure	moulded, V0 flammability rating	
Terminals	tin-plated copper	
Terminal studs	stainless steel	
Max. tightening torque	15 Nm (for M8 studs)	
Dimensions	163 mm x 73 mm x 35 mm	
Mass	≤ 250 g	
Recommended cross sections	current ratings [A]	cable cross section [mm ²]
	75	25
	100	35
	125	50
	150	50
	175	70
	200	95

Approvals

Approval authority	Logo	Directive
KBA	E1 10R-05 7759	ECE R10 Rev. 05
	CE	2004/108/EG

Conformity



Tests

Chemical resistance	ISO 16750-5; 2010 (interior, under the hood, exterior)
Vibration resistance	ISO 16750-3: 2012 (test VIII)
Mechanical Shock	ISO 16750-3: 2012 (Test for devices on rigid points on the body and on the frame)
Corrosion resistance	ISO 16750-4; 2010 (5.5.1 severity level 4)
Humidity	ISO 16750-4 2010 (5.6.2.3)
Temperature change	ISO 16750-4; 2010 (5.3.1)
Electromagnetic	Regulation no. 10 of the United Nations Economic Commission Compatibility (EMC) for Europe (UN/ECE) – Harmonisation of vehicle regulations regarding electromagnetic compatibility EN 61000-6-2: 2005 EN 61000-6-3: 2007
Electrostatic Discharge (ESD)	EN 61000-6-2: 2005 EN 61000-6-3: 2007
Humidity	ISO 16750-4; 2010
Temperature shock	ISO 16750-4; 2010 (Ice water shock test; submersion test)
Free fall	ISO16750-3; 2012
Degree of protection	IP57 (except terminals of load circuit)
Material	moulded enclosure including epoxy with flammability rating VO UL 94: 1996

Order numbering code

Type No.	EPR10 Electronic Power Relay
Protective function	N0 without protection P2 overcurrent trip at 1.3 x In after 200 ms P5 overcurrent trip at 1.3 x In after 500 ms P7 overcurrent trip at 1.3 x In after 700 ms
Design	F1 flat design
Terminals / control cable	G1 M8 terminal studs / Tyco connectors (HDSCS) with 2 M8 nuts
Load and control	HS HSS
Version	S0 standard
System voltage	D2 DC 12 V / 24 V
Current ratings (at 25°C)	75 A protected version only 100 A both versions 125 A protected version only 150 A protected version only 175 A protected version only 200 A both versions
Ordering example	EPR10 - P7 F1 G1 - HS S0 D2 - 200A

5

Time/current characteristic ($T_{amb} = 25\text{ °C}$)

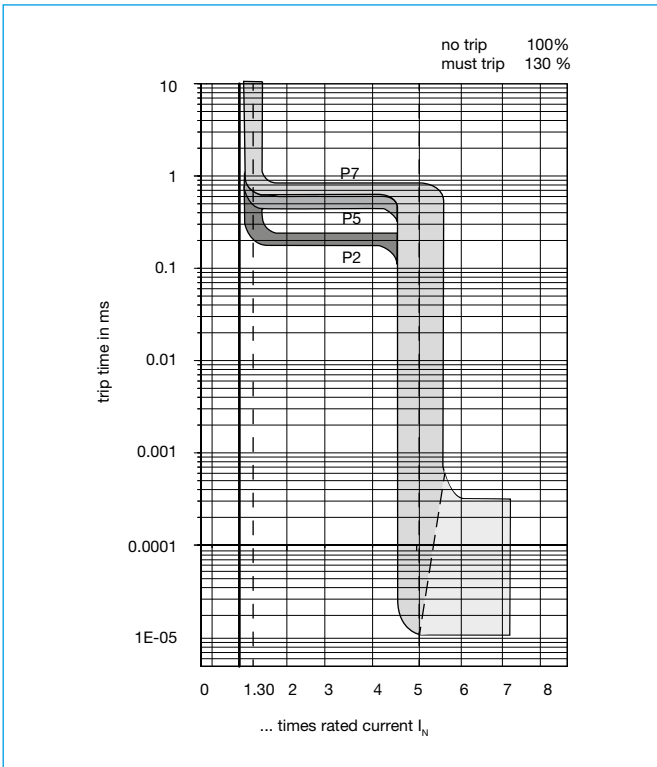

Derating curve

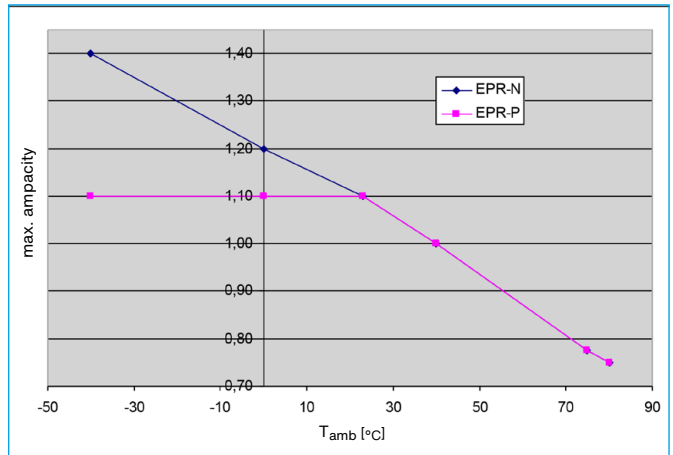

Schematic diagram

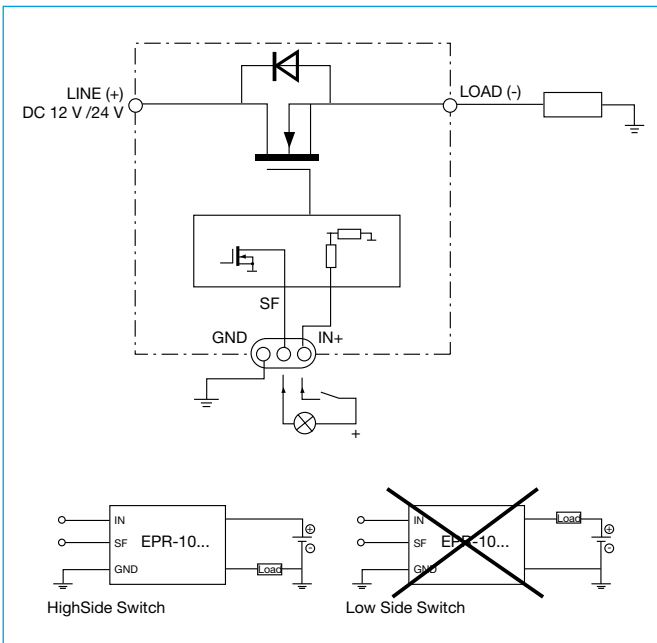

Dimensions

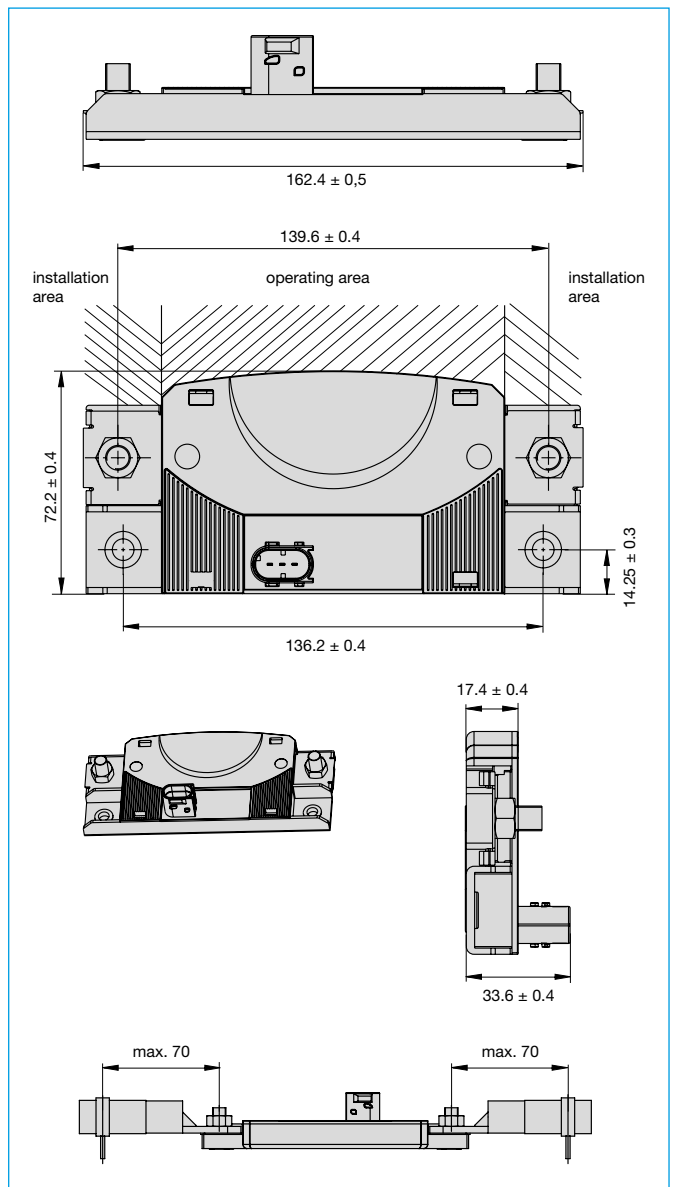

5

All dimensions without tolerances are for reference only. E-T-A reserves the right change specifications at any time in the interest of improved design, performance and cost effectiveness, the right to make changes in these specifications without notice is reserved. Product markings may not be exactly as the ordering codes. Errors and omissions excepted.