

Description

Single, two, three and four pole magnetic and hydraulic-magnetic circuit breakers with trip-free mechanism and toggle actuation. A choice of fast magnetic only or hydraulically delayed switching characteristics (S-type MO or HM CBE to EN 60934) ensures suitability for a wide range of applications. Featuring a combi-foot design for symmetric and asymmetric rail mounting. Low temperature sensitivity at rated load. Approved to CBE standard EN 60934 (IEC 60934).

Typical applications

Power supplies, control equipment, communication systems, EDP systems.

Standard current ratings and typical internal resistance values

Current rating (A)	Curves and internal resistance per pole (Ω)			
	F1	F2	K1, M1, T1	K2, M2, T2
0.02	1493	953	2669	2457
0.05	276	152	452	376
0.1	58	37	100	94
0.25	8.2	6.0	15.5	14.7
0.5	2.3	1.47	3.9	3.2
0.75	0.98	0.63	1.65	1.56
1	0.58	0.35	0.95	0.90
2	0.145	0.096	0.26	0.20
2.5	0.096	0.061	0.15	0.15
3	0.065	0.048	0.10	0.10
5	0.025	< 0.02	0.042	0.040
6	< 0.02	< 0.02	0.029	0.028
8	< 0.02	< 0.02	< 0.02	< 0.02
10	< 0.02	< 0.02	< 0.02	< 0.02
12	< 0.02	< 0.02	< 0.02	< 0.02
15	< 0.02	< 0.02	< 0.02	< 0.02
16	< 0.02	< 0.02	< 0.02	< 0.02
20	< 0.02	< 0.02	< 0.02	< 0.02
25	< 0.02	< 0.02	< 0.02	< 0.02
30	< 0.02	< 0.02	< 0.02	< 0.02
40	≤ 0.01	-	≤ 0.01	-
50	≤ 0.01	-	≤ 0.01	-

Approvals

Authority	Voltage ratings	Current ratings
VDE (EN 60934)	3 AC 415 V; AC 240 V; DC 80 V	0.02...30 A 1 to 6-pole 0.02...50 A 1-pole
UL1077, CSA	DC 80 V 3 AC 250 V; AC 250 V	0.02...50 A 1 to 6-pole 0.02...30 A 1 to 6-pole
UL 489 A	DC 80 V	0.05...30 A 1, 2-pole
CCC	3 AC 415 V; AC 240 V DC 80 V	0.02...30 A 0.02...50 A 1, 2-pole

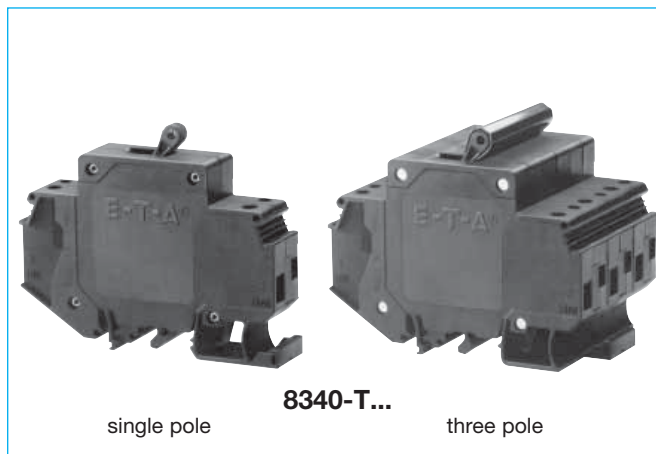

single pole **8340-T...** three pole

Technical data

For further details please see chapter: Technical Information

Voltage rating	3 AC 415V; AC 240V (50/60Hz); DC 80V (higher DC voltages to special order)		
Current rating range	0.02...50 A single pole (40 + 50 A DC only) 0.02...30 A multipole		
Auxiliary circuit	1 A, AC 240 V/DC 65 V; 0.5 A DC 80 V		
Typical life	3 AC 415 V AC 240 V: 0.02...30 A 6,000 operations at $1 \times I_N$, inductive 10,000 operations at $1 \times I_N$, resistive		
WDC 80 V:	0.02...25 A 6,000 operations at $1 \times I_N$, inductive 0.02...30 A 10,000 operations at $1 \times I_N$, resistive 40 + 50 A 6,000 operations at $1 \times I_N$, resistive		
Ambient temperature	-40...+85 °C (-40...+185 °F)		
Insulation co-ordination (IEC 60664 and 60664A)	rated impulse withstand voltage 2.5 kV reinforced insulation in operating area	pollution degree 2	
Dielectric strength (IEC 60664 and 60664A)	test voltage operating area pole to pole main to aux. circuit	AC 3,000 V AC 1,500 V AC 1,500 V	
Insulation resistance	> 100 M Ω (DC 500 V)		
Interrupting capacity I_{cn}	1,200 A at AC; 2,000 A at DC		
Interrupting capacity (UL 1077)	I_N	0.02...20 A	25...30 A
	AC:	1-pole AC 250 V/3,500A 2-pole AC 250 V/3,500A 3-pole 3AC 250V/3,500A	AC 250 V/3,500A AC 250 V/5,000A 3AC250V/5,000A
	DC:	1-pole 0.02...50 A 2-pole 0.02...30 A	DC 80 V/3,500 A DC 80 V/3500 A
Interrupting capacity (UL 489A)	2,000 A		
Degree of protection (IEC 60529/DIN 40050)	operating area IP40 terminal area IP20		
Vibration	with toggle down: directions 1, 2, 3, 4, 5: with curves F1, F2:		
	10 g at $0.9 I_N$ 10 g at $1 \times I_N$ 10 g at $0.8 \times I_N$ in all planes. (57-2000 Hz) ± 0.76 mm (10-57 Hz) to IEC 60068-2-6, test Fc 10 frequency cycles/axis		
Shock	directions 1, 2, 3, 4, 5: direction 6: with curves F1, F2:		
	100 g (11 ms) at $1 \times I_N$ 100 g (11 ms) at $0.8 \times I_N$ 100 g (11 ms) at $0.8 \times I_N$ to IEC 60068-2-27, test Ea		
Corrosion	96 hours at 5 % salt mist, to IEC 60068-2-11, test Ka		
Humidity	240 hours at 95 % RH, to IEC 60068-2-78, test Cab		
Mass	approx. 98 g per pole		

Ordering information

Type No.									
8340	circuit breaker with toggle actuator								
Mounting									
T rail mounting									
Configuration									
1 snap-on installation									
Number of poles									
0	single pole, switch only								
1	single pole protected								
2	two pole protected	} magnetic, hydraulic-magnetic							
3	three pole protected								
4	four pole protected								
5	two pole, protected on one pole only								
6	four pole, protected on poles 1, 2 and 3 only								
7	two pole, switch only								
Panel hardware									
0 without panel hardware									
Terminal design (main contact)									
K1 recessed screw/pressure plates M4									
Characteristic curve									
Curve F, instantaneous trip:									
F1	DC	trip at 1.01-1.5 x I _N							
F2	AC 60/50 Hz	trip at 1.01-1.5 x I _N							
Curve K, short delay:									
K1	DC	trip at 2 x I _N	0.16-1.2 s						
K2	AC 60/50 Hz	trip at 2 x I _N	0.13-1.6 s						
Curve M, medium delay:									
M1	DC	trip at 2 x I _N	0.6-7.5 s						
M2	AC 60/50 Hz	trip at 2 x I _N	2.2-20 s						
Without characteristic curve									
Q0 switch only									
Curve T, long delay:									
T1	DC	trip at 2 x I _N	10-70 s						
T2	AC 60/50 Hz	trip at 2 x I _N	15-150 s						
Other characteristic curves to special order (e.g. pulse-delayed, high inrush currents, capacitive loads)									
Actuator colour / design									
A black, long toggle									
B white, long toggle									
C blue, long toggle									
K black, short toggle									
L white, short toggle									
M blue, short toggle									
other colours to special order									
Marking on actuator									
0 without marking									
L I-O; ON-OFF									
M I-O; ON-OFF (I _N , U _N , trip curve, schematic diagram on housing top)									
N I-O; ON-OFF (I _N , on housing top)									
Auxiliary contacts									
H0 without auxiliary contacts									
H1 with auxiliary contact									
H2 with auxiliary contact on one pole only (multipole)									
Auxiliary contact function (see internal connection diagrams)									
2 1 N/O contact									
3 1 N/C contact									
Auxiliary contact terminal design									
6 screw/pressure plate M3									
Current ratings									
0.02...50 A									
Approval (optional)									
U UL 489 A									

8340 - T 1 1 0 - K1 M1 - A L H1 2 6 - 10 A - U ordering example

Dimensions

long toggle

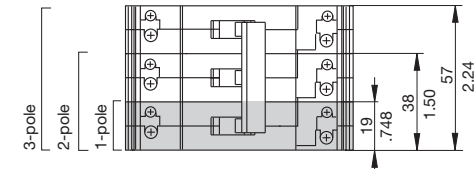
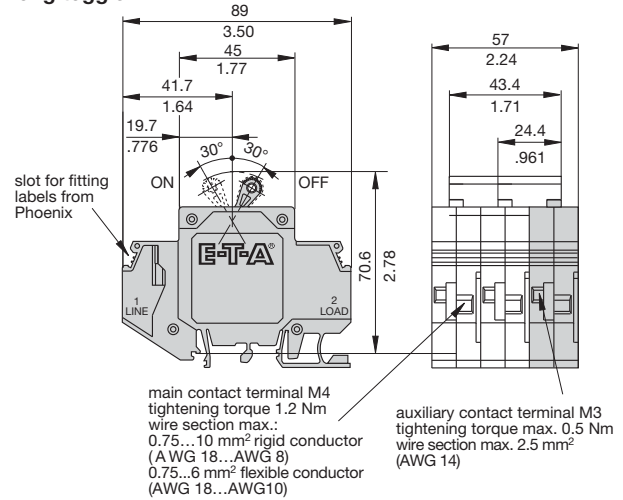

short toggle

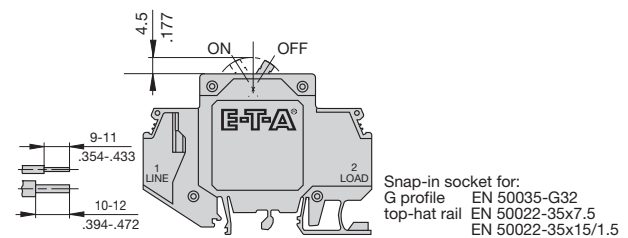

Installation drawing

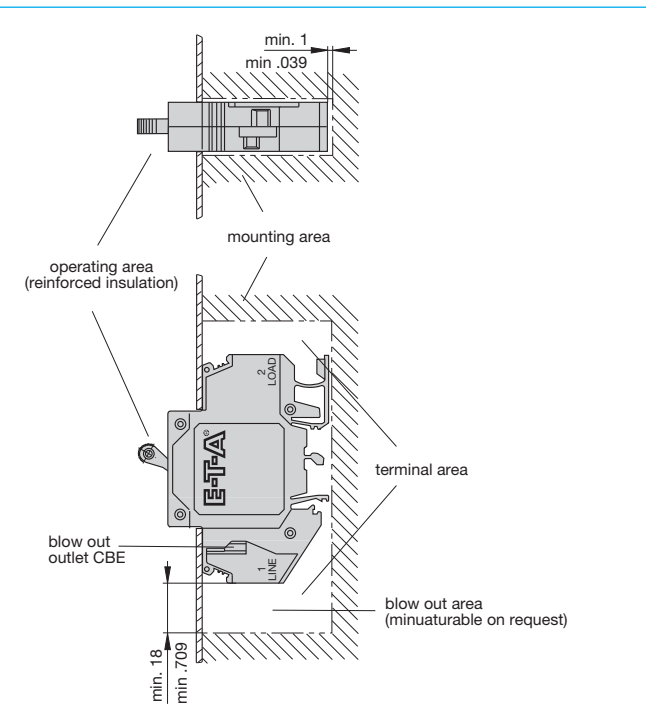

This is a metric design and millimeter dimensions take precedence (mm/inch)

Internal connection diagrams

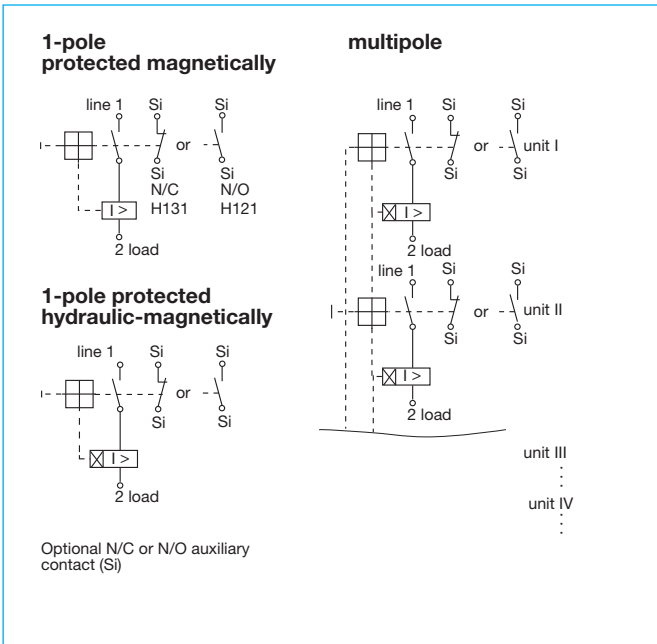

Shock directions

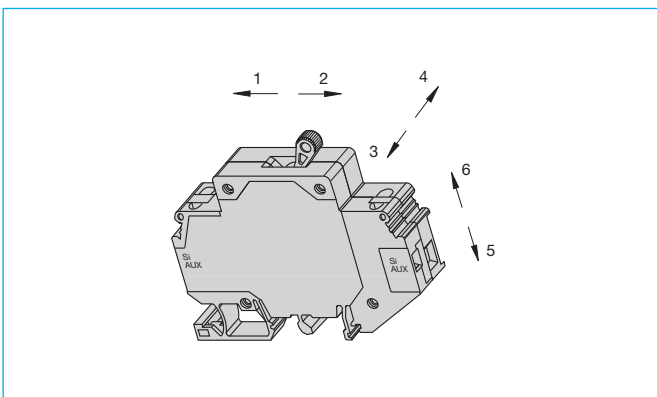

Typical time/current characteristics at 23 °C / +73.4 °F

Curve T1 (long delay) for DC

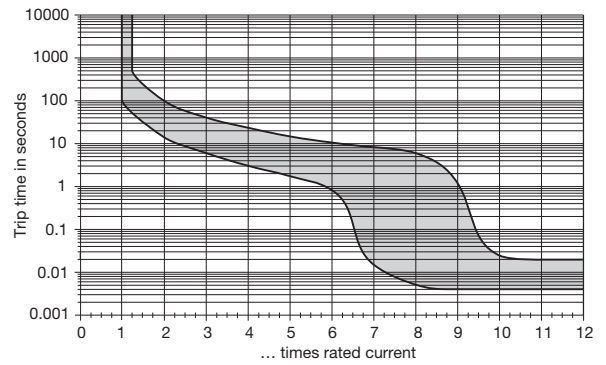

Curve T2 (long delay) for AC 50/60 Hz

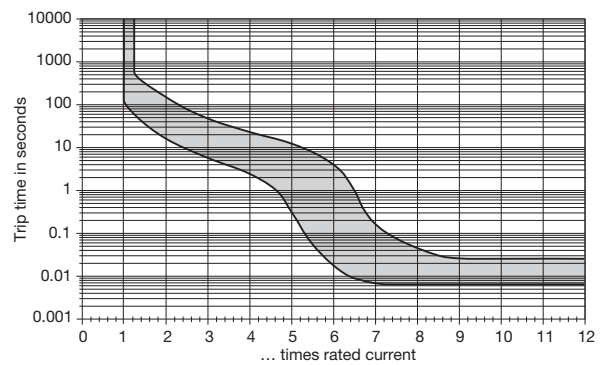

N.B. All curves will only be maintained if the escutcheon is mounted on a vertical surface.

Other characteristic curves to special order (e. g. with impulse delay for inrush peaks).

Typical time/current characteristics at 23 °C / +73.4 °F

Curve F1 (instantaneous) for DC

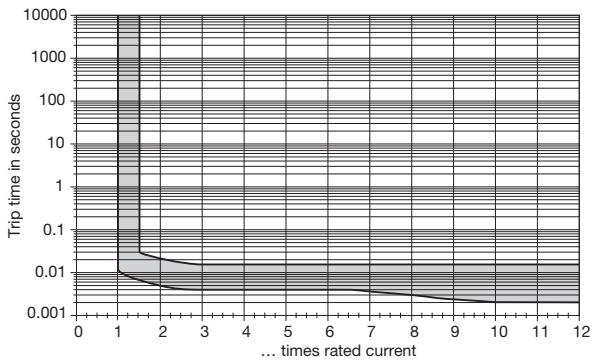

Curve M0 (medium delay) for AC/DC

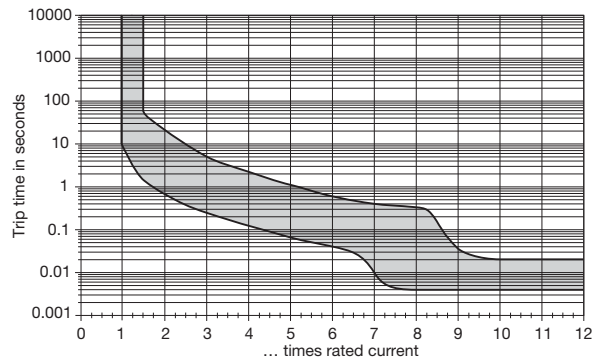

Curve F2 (instantaneous) for AC 50/60 Hz

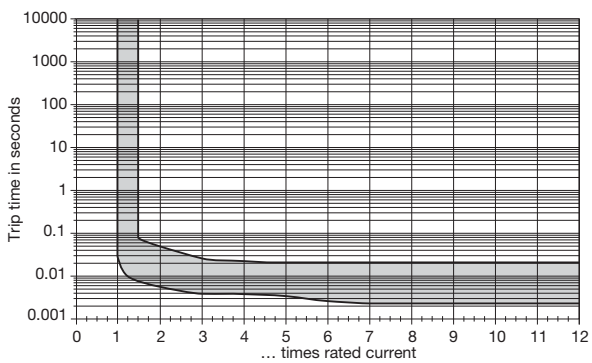

Curve M1 (medium delay) for DC

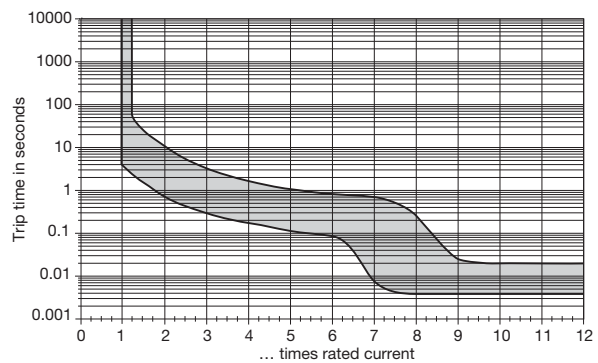

Curve K1 (short delay) for DC

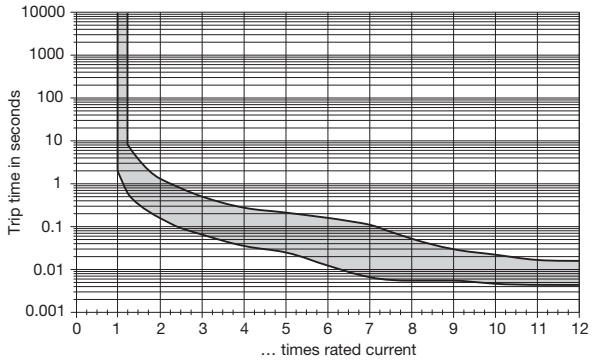

Curve M2 (medium delay) for AC 50/60 Hz

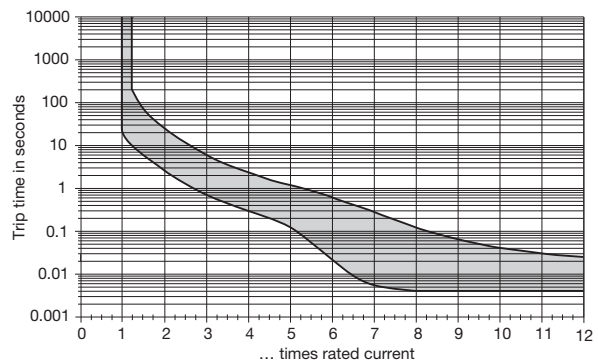

Curve K2 (short delay) for AC 50/60 Hz

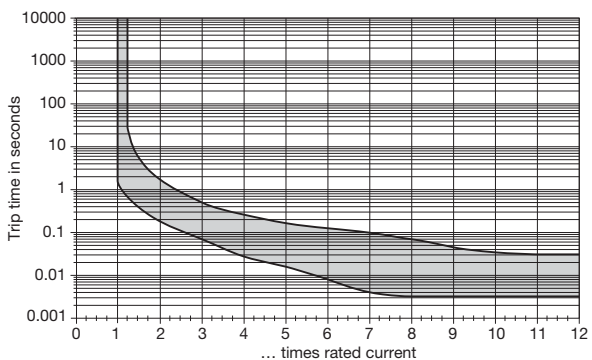

N.B. All curves will only be maintained if the escutcheon is mounted on a vertical surface.

Other characteristic curves to special order (e. g. with impulse delay for inrush peaks).

3

Accessories

Connector bus links -K10

X210 589 01/2.5 mm², (AWG 14) (black) up to 20 A max. load
X210 589 02/1.5 mm², (AWG 16) (brown) up to 13 A max. load

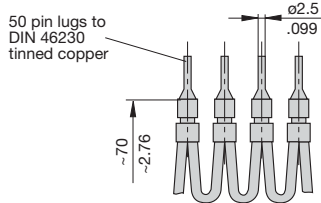

Busbar 1-pole
Y 308 495 01

The one metre long busbars can be cut to suitable lengths. Plug-on caps can be fitted on the ends to provide brush contact protection.

I_{max} - busbar 100 A (40 °C)

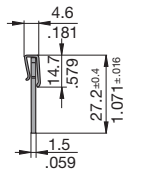
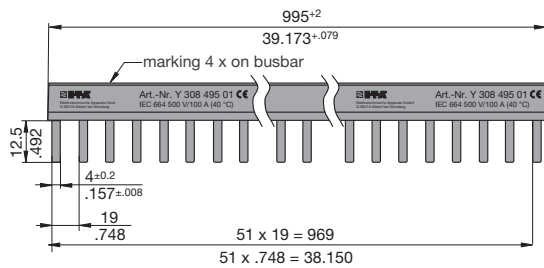

Plug-on cap, 1-pole
Y 307 851 01



Busbar 2-pole
Y 308 496 01

I_{max} - busbar 100 A (40 °C)

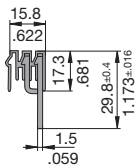
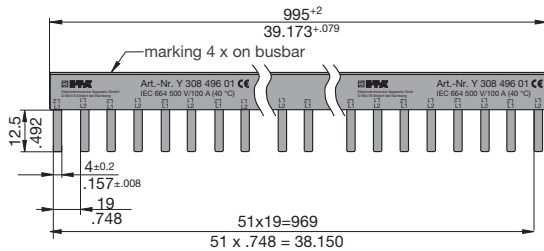

Plug-on cap, busbar 2/3-pole
Y 308 506 01

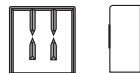

Busbar 3-pole
Y 308 497 01

I_{max} - busbar 100 A (40 °C)

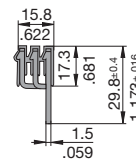
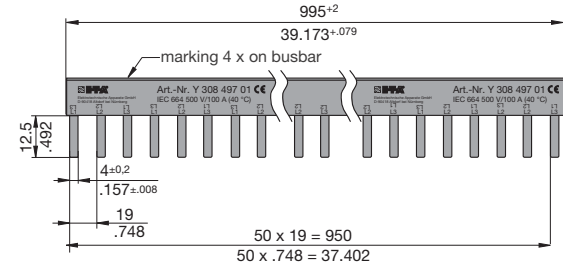

Plug-on cap, busbar 2/3-pole
Y 308 506 01

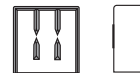

Supply terminal I_{max} 63 A

Y 308 504 01

Max. tightening torque of terminal screw 2 Nm
 Max. cable cross section: 25 mm² / single strand
 16 mm² / multistrand with wire end ferrule

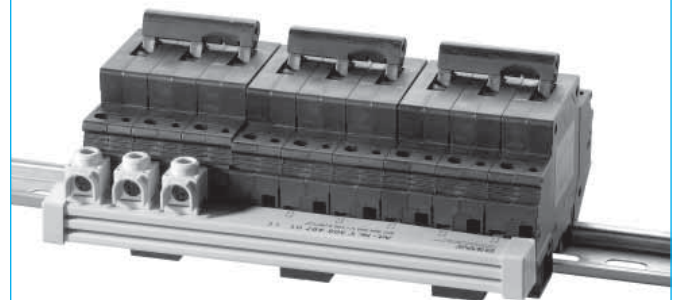
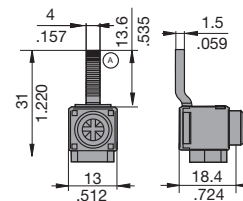

Caution:

When using multipole busbars please leave at least one pole's width between two adjacent line entry terminals.

This is a metric design and millimeter dimensions take precedence (mm/inch)

All dimensions without tolerances are for reference only. In the interest of improved design, performance and cost effectiveness the right to make changes in these specifications without notice is reserved. Product markings may not be exactly as the ordering codes. Errors and omissions excepted.