

Description

The Smart Power Relay E-1048-8D. is a remotely controllable electronic load disconnecting relay with two functions in a single unit:

- electronic relay
- electronic overcurrent protection

The 4 pin DICE version is designed for use with standard automotive relay sockets. A choice of current ratings is available from 1 A through 30 A. An operating voltage range of DC 9...32 V allows the connection of DC 12 V and DC 24 V loads.

In order to switch and protect loads remotely, it has until now been necessary to connect several discreet components together:

- an electro-mechanic relay, control cable and integral contact to close the load circuit
- an additional protective element (circuit breaker or fuse) for cable or equipment protection

Now type E-1048-8D. combines these two functions in a single unit, thus minimising the number of connections in the circuit and thereby reducing the risk of failures.

Applications

Type E-1048-8D. is suited to all applications with DC 12 V or DC 24 V circuits, where magnetic valves, motors or lamp loads have to be switched, protected or monitored:

- road vehicles (utility vehicles, buses, special vehicles)
- construction and agricultural machinery
- rail vehicles
- marine industry (ships, boats, yachts etc.)

The Power Relay is also suitable for industrial use (process control, machine-building, engineering) as an electronic coupling relay between PLC and DC 12 V or DC 24 V load

Features

- Integral power electronics provide a wear-resistant switching function, insensitive to shock, vibration and dust.
- Compared to electro-mechanical relays, only a fraction of the closed-circuit current or switching current is needed. This is important for battery buffered load circuits which have to remain controlled even with the generator off line.
- The extremely low induced current consumption of less than 100 µA is absolutely necessary for battery buffered applications.
- The load circuit is disconnected in the event of a short circuit (ENTRY version) or overload/short circuit (ENTRYprotect version).
- For switching and monitoring loads of 30 A plus it is possible to connect several units in parallel. Uniform power distribution between units must be ensured by symmetrical design of the supply cables (length and cross section).
- Coloured label, e. g. red = 10 A, see ordering information.



E-1048-8D. DICE version

Technical Data ($T_{amb.} = 25\text{ °C}$, $U_N = DC\ 24\ V$)

Power supply LINE +

Type	DC power supply with small R_i battery and generator etc.
Voltage ratings U_N	DC 12 V/DC 24 V
Operating voltage U_S	DC 9...32 V

Load circuit LOAD

Load output	Power MOSFET, High Side Switch (HSS) or Low Side Switch (LSS)
Max. current rating I_N	30 A
Types of loads	resistive, inductive, capacitive, lamp loads, motors (depending on duration of inrush current)
Current rating range I_N	1 A...30 A (fixed ratings) up to 85 °C ambient without load reduction, 25 A...30 A up to 80 °C
ENTRY version	Load output with short circuit protection
ENTRYprotect version	Load output with short circuit and overload protection (typically 200 ms at $I_{Load} > \text{typically } 1.3 \times I_N$)
	$I_N = 1\text{ A...}10\text{ A}$: see trip curve 1
	$I_N = 15\text{ A...}30\text{ A}$: see trip curve 2

Induced current consumption I_0 of the unit (OFF condition)	typically 100 µA
Typical voltage drop U_{ON} at rated current I_N (at 25 °C)	

I_N	U_{ON}	I_N	U_{ON}
1 A	50 mV	10 A	110 mV
2 A	55 mV	15 A	70 mV
3 A	60 mV	20 A	90 mV
5 A	80 mV	25 A	120 mV
7.5 A	90 mV	30 A	140 mV

Switching point	typically $1.3 \times I_N$
(only ENTRYprotect)	(-40 °C...+85 °C: $1.1...1.5 \times I_N$)
Trip time (standard curve)	typically 200 ms with switch-on onto overload and/or load increase on duty
(only ENTRYprotect)	
Current limitation	$I_N = 1\text{ A...}10\text{ A}$: typically 60 A $I_N = 15\text{ A...}30\text{ A}$: typically 200 A
Temperature disconnection	power transistor > 150 °C
After trip	- resettable via external control signal (low-high) at control input IN+ or IN- - reset of supply voltage
Parallel connection of channels	for loads of 30 A plus, several units of identical current ratings may be connected in parallel. To ensure equal distribution of current between units, symmetrical design of the supply feed is necessary (length and cross section).
Leakage current in OFF condition	$I_N = 1\text{ A...}10\text{ A}$: max. 100 µA $I_N = 15\text{ A...}30\text{ A}$: max. 500 µA

Technical Data ($T_U = 25\text{ }^\circ\text{C}$, $U_S = \text{DC } 24\text{ V}$) ($T_U = \text{ambient temperature at } U_N$)

Free-wheeling diode for connected load	integral $I_N = 1\text{ A} \dots 10\text{ A}$: max. 40 A $I_N = 15\text{ A} \dots 30\text{ A}$: max. 100 A
Delay time t_{on} / t_{off} (resistive load)	typically 0.5 ms / typically 1.5 ms (EMC filter in control input)
Short circuit, overload in load circuit	- disconnection of load - no automatic re-start - after remedy of the fault unit has to be reset via control input IN+

Control input IN+

Control voltage IN+	0...5 V = "OFF", 8.5...32 V = "ON"
Control current I_E	typically 1 mA at 12 V / typically 5 mA at 24 V
Reset in the event of a failure	- reset via external control signal (low-high) at control input IN+ - via reset of supply voltage possible, see max. switching frequency
Dimmer operation (e.g. PWM signal)	
Switching frequency at resistive or inductive load	max. 100 Hz

Control input IN-

Control voltage IN-	relay energised when IN- connected to ground; tolerance range 12 V system: 0...6 V = "ON" 8.5...12 V "OFF" tolerance range 24 V system: 0...18 V = "ON" 20.5...24 V "OFF"
Reset in the event of a failure	- resettable via external control signal (High-Low) at control input IN- - via reset of supply voltage
Rising edge of IN	< 5 ms

General data

Reverse polarity protection

Control circuit	yes
Load circuit	no (due to integral free-wheeling diode)

Temperature range

ambient temperature	- standard: -40...+85 °C
---------------------	--------------------------

Tests

Humid heat	combined test, 9 cycles with functional test test to DIN EN 60068-2-30, Z/AD
Temperature change	min. temperature -40 °C, max. temperature +90 °C test to DIN IEC 60068-2-14, Nb in operation, with temperature change
Vibration (random)	6 g eff. (10 Hz...2,000 Hz) test to DIN EN 60068-2-64
Shock	25 g/11 ms, 10 shocks test to DIN EN 60068-2-27
Corrosion	test to DIN EN 60068-2-52, severity 3
Protection class	housing -8D4 IP30 to DIN 40050 housing -8D5 IP54 to DIN 40050, higher protection class upon request
EMC requirements	EMC directive: emitted interference EN 50081-1 noise immunity EN 61000-6-2 Automotive directive: emitted interference, noise immunity: 72/245/EWG and 2006/28/EG

Terminals (4 pin)

Mounting:	4 blade terminals 6.3 mm x 0.8 mm contact material CuZn37F44 - on automotive relay socket 4-pole
-----------	--

Housing

max. dimensions	30 x 30 x 30 mm when plugged in 30 x 30 x 41.6 mm including terminals
Materials	housing PA66-GF30 base plate PA6-GF30
Mass	approx. 20 g

Technical Data ($T_U = 25\text{ }^\circ\text{C}$, $U_S = \text{DC } 24\text{ V}$) ($T_U = \text{ambient temperature at } U_N$)

Approvals

CE, e1 logo:	to EMC directive and vehicles directive Approved by Kraftfahrt-Bundesamt approvals no. e1 035636
--------------	--

Ordering Information

Type

E-1048-8D Smart Power Relay DC 12 V/24 V, 1 A...30 A in DICE version

Housing / temperature range	
4	with housing -40 °C...85 °C (for rated current up to 20 A)
Control input	
C0	with control input (+ control 8.5...32 V)
C1	with control input (+ control by connecting to ground)
Options	
A0	without options
Characteristic curve	
0	ENTRY, short circuit protected
4	ENTRYprotect, 200 ms standard switch-off delay with overload, short circuit protected
Voltage rating	
U3	DC 12/24 V
Current ratings / colour of label	
	1 A / black
	2 A / grey
	3 A / purple
	5 A / light-brown
	7.5 A / brown
	10 A / red
	15 A / blue
	20 A / yellow
	25 A / white
	30 A / green

E-1048-8D 4 - C0 A0 - 0 U3 - 10 A ordering example: ENTRY version 4 pin

Preferred types

NEW

Preferred types	Standard current ratings (A)							
	1	2	3	5	7.5	10	15	20
E-1048-8D4-C0A0-4U3-	x	x	x	x	x	x	x	x

Dimensions DICE version (4 pin version)

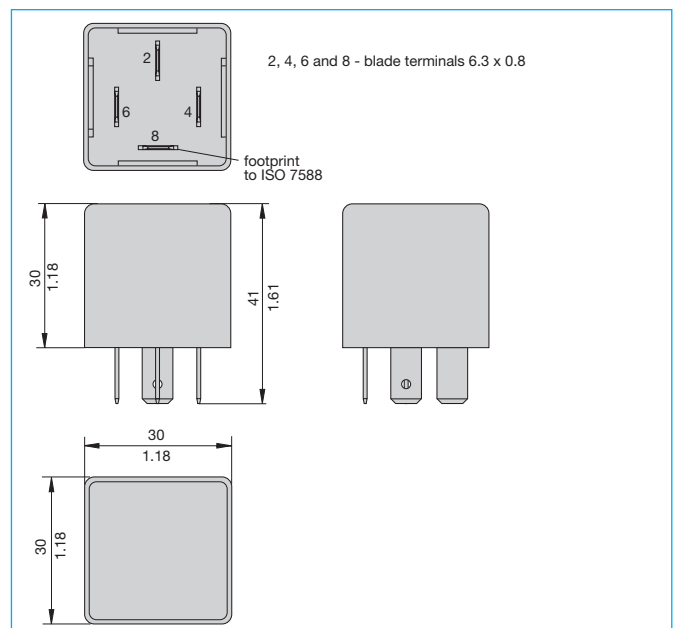

Typical time/current characteristics ($T_A = 25^\circ\text{C}$)

Trip curve 1 "ENTRYprotect"

1 A, 2 A, 3 A, 5 A, 7,5 A and 10 A (standard 200 ms)

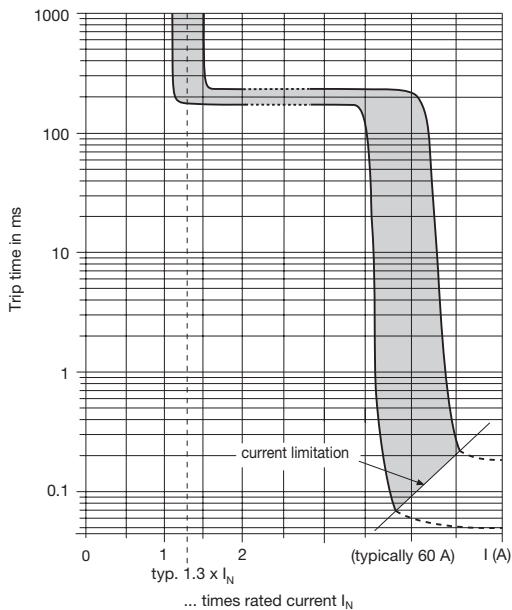

Trip curve 2 "ENTRYprotect"

15 A, 20 A, 25 and 30 A (standard 200 ms)

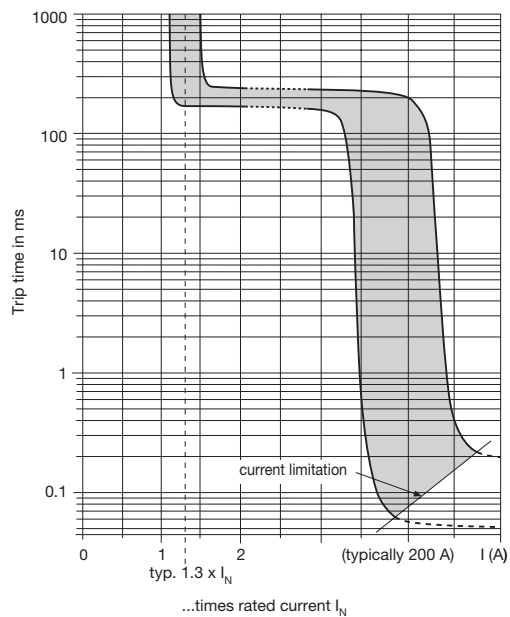

Connection diagrams DICE version

C0 Control Input IN+

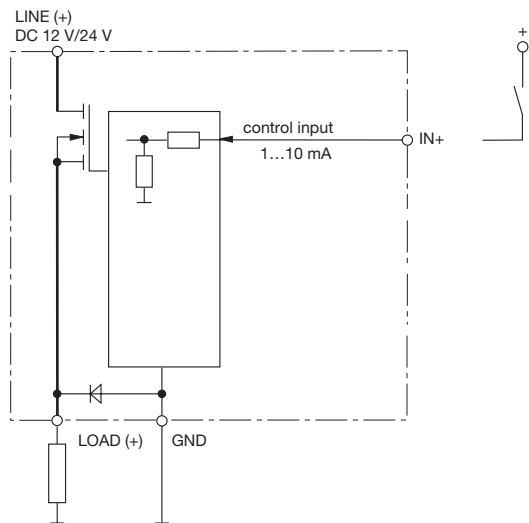

C0 Control Input IN-

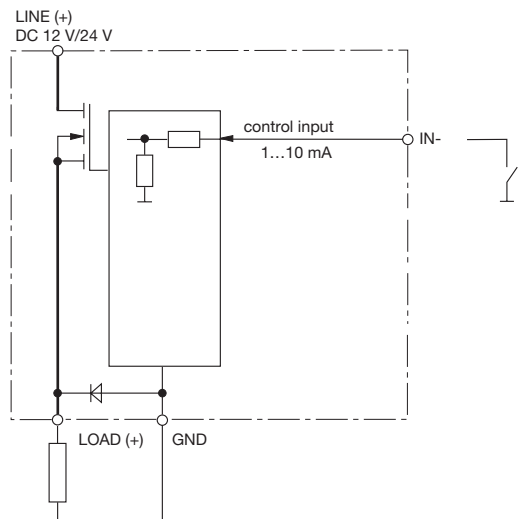

Pin selection DICE version (4 pin)

E-1048-8D. DICE version

LINE +	(1)	plus U_S (DC 12 V/24 V)
	(2)	
	(3)	
IN (4)	(4)	control input
GND	(5)	
	(6)	minus U_S
LOAD	(8)	load output

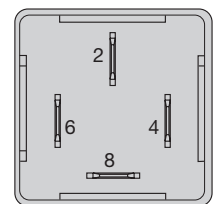

This is a metric design and millimeter dimensions take precedence ($\frac{\text{mm}}{\text{inch}}$)

All dimensions without tolerances are for reference only. In the interest of improved design, performance and cost effectiveness the right to make changes in these specifications without notice is reserved. Product markings may not be exactly as the ordering codes. Errors and omissions excepted.