

Description

Single pole thermal circuit breaker with push-to-reset, tease-free, trip-free, snap action mechanism and separate manual release (M-type TO CBE to EN 60934). Designed for bolt-on mounting with terminal block type 83-P10.

Typical applications

Extra low voltage wiring systems on all types of vehicles and marine craft.

Ordering information

Type No.

129 base mounting and connection

Terminal design

L11 90° bent terminals

Manual release

H manual release facility

Housing

KF standard

Current ratings

3...25 A

129 - L11 - H - KF - 10 A = ordering example

Standard current ratings and typical internal resistance values

Current rating (A)	Internal resistance (Ω)	Current rating (A)	Internal resistance (Ω)
3	0.1	8	0.02
3.5	0.06	10	< 0.02
4	0.06	12	< 0.02
4.5	0.05	16	< 0.02
5	0.05	20	< 0.02
6	0.02	25	< 0.02
7	0.02		

Approvals

Authority	Voltage ratings	Current ratings
CSA, UL	AC 250 V DC 50 V	3...20 A 3...25 A
BWB (VG 95345 part 9)	DC 28 V	6...25 A



129-L11-H-KF

Technical data

Voltage rating	DC 28 V (UL: AC 250 V; DC 50 V)		
Current ratings	3...25 A		
Typical life	5,000 operations at $2 \times I_N$		
Ambient temperature	-40...+75 °C (-40...167 °F)		
Insulation co-ordination (IEC 60664 and 60664 A)	rated impulse withstand voltage 2.5 kV	pollution degree 2	
Dielectric strength (IEC 60664 and 60664A) operating area	test voltage AC 1,500 V		
Insulation resistance	> 100 MΩ (DC 500 V)		
Interrupting capacity I_{cn}	3...5 A $20 \times I_N$ 6...25 A 400 A		
Interrupting capacity (UL 1077)	I_N 0.05...25 A	U_N DC 50 V	2,500 A
Degree of protection (IEC 60529/DIN 40050)	operating area IP32 terminal area IP00		
Vibration	10 g (55-2,000 Hz) ± 0.76 mm (10-55 Hz) to VG 95210 part 28		
Shock	50 g (11 ms) to VG 95210 part 28		
Corrosion	96 hours at 5 % salt mist, to VG 95210 part 2		
Humidity	240 hours at 95 % RH to VG 95210 part 7		
Mass	approx. 25 g		

Dimensions

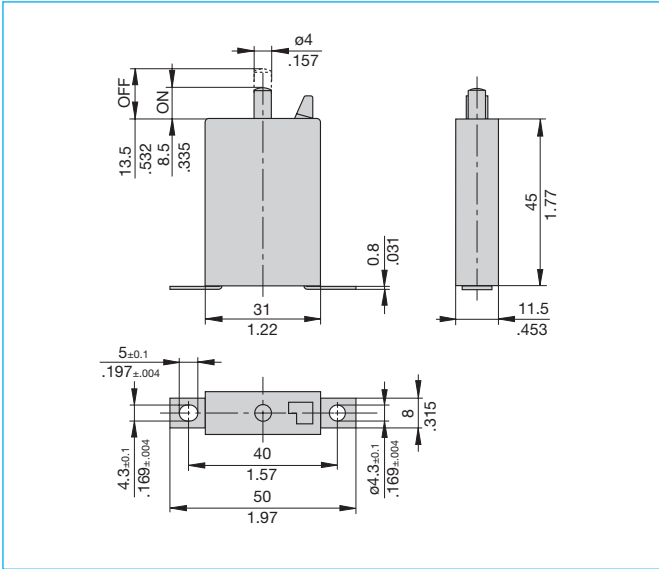

Internal connection diagram

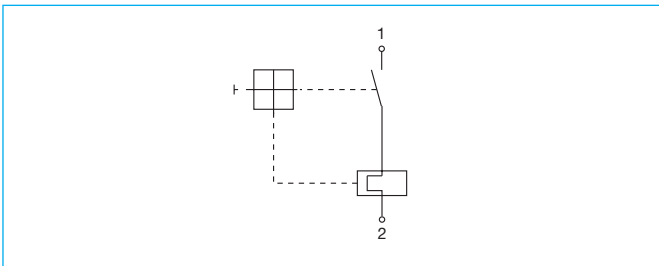

Typical time/current characteristics at +23 °C/+73.4 °F

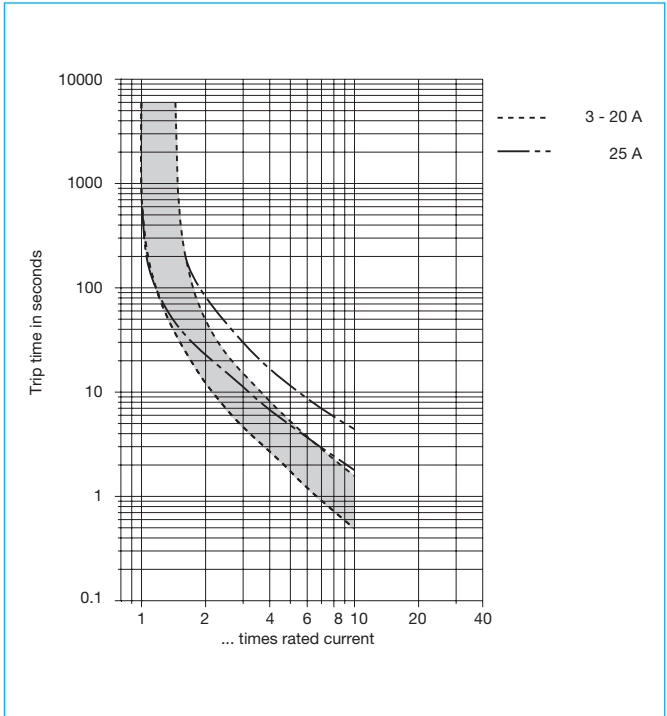

The time/current characteristic curve depends on the ambient temperature prevailing. In order to eliminate nuisance tripping, please multiply the circuit breaker current ratings by the derating factor shown below. See also section Technical information.

Ambient temp. °F	-40	-4	+14	+32	+73.4	+104	+122	+140	+167
°C	-40	-20	-10	0	+23	+40	+50	+60	+75
Derating factor	0.60	0.76	0.84	0.92	1	1.08	1.16	1.24	1.35

This is a metric design and millimeter dimensions take precedence ($\frac{mm}{inch}$)

All dimensions without tolerances are for reference only. In the interest of improved design, performance and cost effectiveness the right to make changes in these specifications without notice is reserved. Product markings may not be exactly as the ordering codes. Errors and omissions excepted.