

E-T-A's DC 24 V Concept A Certain Winner!





With E-T-A you can hold all the aces



Small but powerful

Decentralisation involving the remote distribution of power is the modern approach to factory automation. This demands control cabinets of compact design which impose severe space restrictions when it comes to component selection. "Small but powerful" is a good description for the DC 24 V supply systems needed to supply sensors and actuators.

The advance of Switch Mode Power Supplies

Switch mode power supplies are gaining in popularity over conventional transformers. They are not only more compact but also provide greater reliability and more power – ensuring a competitive edge when in-service availability and operating safety are essential for all automated industrial production and machine control applications.

New methods of protection

However SMPs make their own demands with regard to fault protection. As conventional circuit breakers in this case tend to be too slow in their operation, SMPs are self-protecting and will shut down the power output in the event of overload or short circuit. As a result a fault in just one output circuit may lead to complete disconnection of all loads, causing costly stoppages, other unwanted disruption, and even uncontrolled restarting with all its associated hazards. Neither the cables nor the loads will be adequately protected.

Safety - the winning card

The reliable provision of power without irregularities or interruptions and the prevention of hazardous operating conditions are of paramount importance. E-T-A ESS20 electronic circuit breakers and ESX10 electronic circuit protectors are purpose designed to selectively protect DC 24 V automation circuits to prevent the collapse of the supply voltage. Their reliable operation is independent of adverse load conditions, long cable runs and even cables of small cross-sectional area.

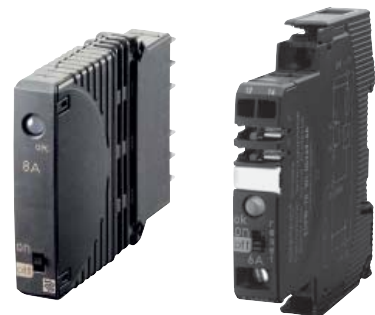

Electronic circuit protector ESX10, ESX10-T



Electronic circuit breaker ESS20



ESS20 – Physical isolation for complete safety

Type ESS20 provides a combination of electronic and thermal tripping characteristics to ensure selective physical disconnection of the circuit both in the event of a failure or during start up or diagnosis of individual loads. As the performance of the ESS20 will facilitate compliance of plant and equipment with European Machinery Directive 98/37/EC, European circuit breaker standard EN 60204-1 and the requirements of UL 1077 in North America, customers will benefit from being able to supply their equipment around the world.

Instant short circuit response

The ESS20 will respond immediately to a short circuit. The overload current will be electronically limited to 1.8 times rated current, the faulty circuit will be electronically disconnected within 100 ms and will then be physically isolated from the power supply. The SMS will not be affected by the short circuit, while the remaining loads will continue to be supplied without any interruption.

Active discrimination

The ESS20 will allow an overcurrent of up to 1.8 times rated current – for a defined time. In the event of a sustained overload the thermal trip mechanism will physically isolate the faulty load circuit from the power supply after a maximum of 5 seconds.

Tolerance of inrush peaks

The high inrush currents associated with capacitive loads of up to 20,000 microfarads will not affect the ESS20 thanks to its integral current limitation. Neither the switch mode power supply nor the remaining loads will be affected by inrush peaks.

ESX10 - electronic disconnection

The ESX10 is designed for systems which feature integral protection functions and do not therefore require physical isolation of DC 24 V circuits. The ESX10 complements the ESS20 in E-T-A's family of DC 24 V protection devices, providing electronic load disconnection under short circuit or overload conditions, with selectivity guaranteed. While the ESX10-T device clips directly onto the DIN rail, different mounting sockets are available for the ESX10 device.

Your benefits:

- selective protection in the event of overload or short circuit
- reliable protection against stoppage and production downtime
- dependable diagnostics and load disconnection
- optimal start-up and plant expansion
- precise signalling and remote control
- integration of trouble-shooting in control and visual indication
- standardised safety according to EN 60204-1, UL 1077, UL 2367, CE





E-T-A's DC 24 V solutions contribute to space, time and cost savings

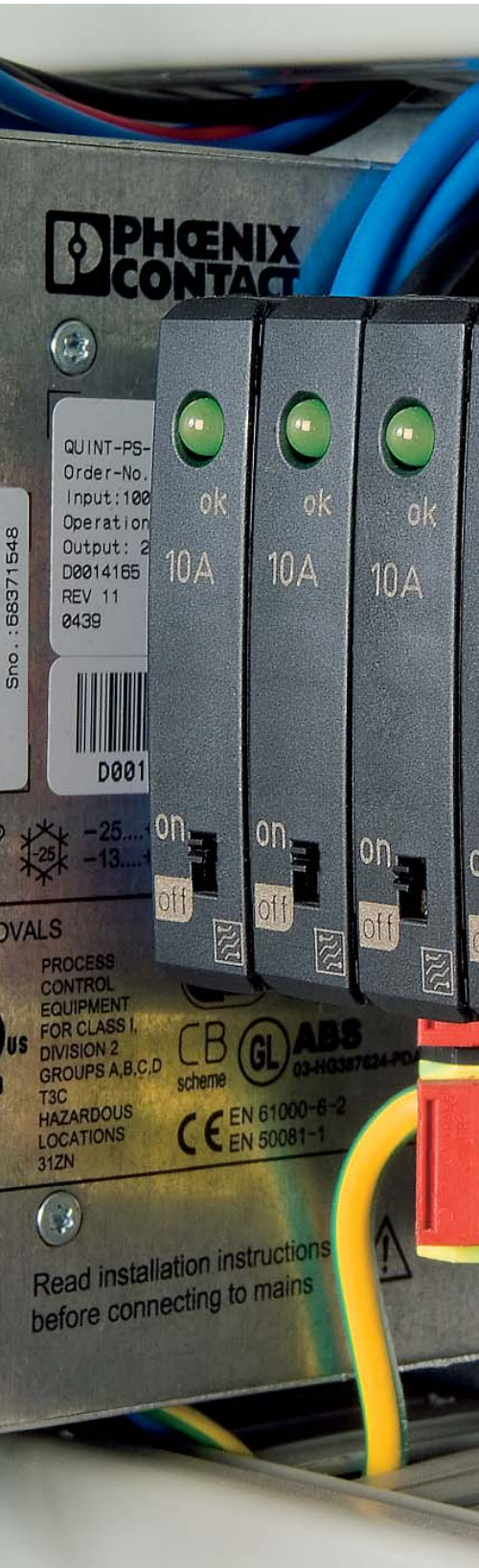

Maximum safety – minimum space

A reliably protected DC 24 V control voltage is just one part of the challenge. Other factors including power distribution, sub-distribution and wiring will influence critical factors such as safety, space requirements and cost. Every millimetre counts in the design of today's compact control cabinets, whether they are remotely sited alongside machinery or are in centralised control and communication systems.



Power distribution system Module 17plus fitted with electronic circuit breaker type ESS20

Efficient power distribution

A well structured DC 24 V power distribution system, efficiently pre-wired and of modular design, will help to optimise the use of space in control cabinets. Input and distribution terminals in a variety of configurations installed directly on the pcb of the distribution system avoid the need for additional sub-distribution. The clear structure of the distribution system facilitates trouble shooting and expansion of the system. EPLAN macros for each component can be effortlessly transported to design drawings and documentation.

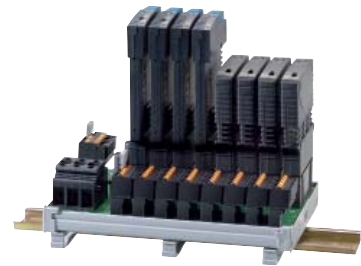

Power distribution system SVS02 fitted with electronic circuit breakers type ESS20 and electronic circuit protectors type ESX10

Flexibility by design

E-T-A DC 24 V circuit breakers and protectors 2210, 3600, ESS20 and ESX10 are simply plugged into the pre-wired sockets of the SVS power distribution systems and may be swapped at any time without having to change the wiring – design features which help to reduce time and cost.

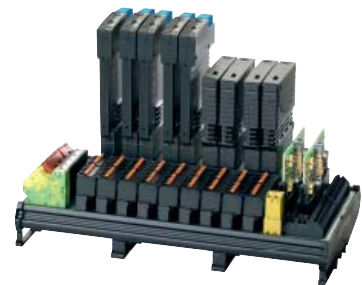

Power distribution system SVS05 with AS-i bus interface, fitted with ESS20 and ESX10 devices

DC 24 V power distribution with our modular SVS concept

Example for assembly (EPLAN macro): power distribution system SVS02-04 with ESS20 and jumper

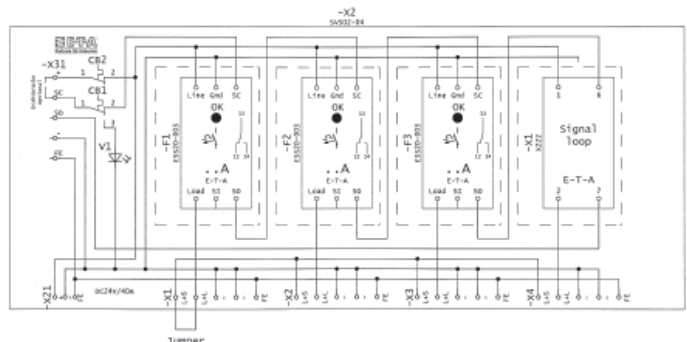



E-T-A: your design partner

Features of the E-T-A system:

- selective load protection according to current rating
- convenient symmetric DIN rail mounting of all DC 24 V sockets
- adjacent double sockets of module 17 plus
- customised SVS power distribution system with 4-20 sockets
- circuit monitoring with discrete or group status signals
- multiple terminals for supply feed, load and minus potentials, and signalisation
- integral protection of group signalisation
- integral AS-i bus interface for alarm signalisation (SVS05)
- cascadable 10-slot distribution boards based on master/slave principle
- integral acknowledgement (local/remote) of alarm signal and separate reset function (SVS09)
- sockets for electronic circuit breakers or protectors ESS20 and ESX10 as well as for thermal-magnetic E-T-A circuit breakers type 2210 and type 3600
- EPLAN macros aid design, construction and documentation



ESS20 plugged into Module 17plus



Your benefits:

- systematic integration of protection and distribution functions
- high rate of flexibility and safety
- clearly laid out distribution and sub-distribution concept
- reduction in planning, construction and installation times
- ease of maintenance, diagnostics and system expansion
- compact power distribution for compact control cabinets



System safety assured



The reliability of DC 24 V power supplies in control cabinets is of paramount importance for sophisticated production lines and process control, with round the clock stoppage from production the aim for such capital investments. Reliable on-

line availability necessitates well planned protection of the system including the DC 24 V control circuitry. The E-T-A DC 24 V protection and distribution concept can be found in all types of process and environmental applications.

Automotive

Integrated factory automation with decentralised control systems for robot applications, chuck tools, machine operator work stations and drive units is vital in car manufacturing. Distributed DC 24 V control circuits have to be interconnected, installed and protected. Safe and compact equipment featuring ESS20, ESX10 and E-T-A power distribution systems can be found serving applications in the body shell areas, the paint shop and on final assembly lines.



Steel production and metallurgy

ESS20 and ESX10 in combination with pre-wired power distribution systems provide enhanced safety and production standardisation in the hot dip plants and blast furnaces of leading steel producers, in high-precision manufacturing centres and on the special machine tools and assembly lines of major mechanical engineering companies.



Foodstuffs and pharmaceutical industry

Processing, dosage and metering technology, weighing and mixing, conveying systems and packing machines – all benefit from reliable DC 24 V protection in increasingly automated distributed systems.



Power plants and energy sources

Automation, power distribution and the interconnection of modular functional groups are well established in the energy sector. 24/7 plant availability is essential in applications extending from control technology to field and remote control modules. E-T-A's comprehensive overcurrent protection programme in the field of DC 24 V provide operational reliability, independent of line size, cable length or cross-sectional area.



Chemical plants and bio-engineering

Highly automated processes are the norm in the chemical and bio-engineering industries. Their demanding requirements for product output and failsafe reliability could not be satisfied without the help of advanced protection technology. E-T-A system solutions for DC 24 V applications ensure safety and reliability for even the most demanding applications.

Machine tools

Capital intensive plant and equipment ranging from conventional machine tools and CNC processing machines to highly flexible assembly lines operating 24 hours a day. Continuous production is supported by localised DC 24 V supplies with reliable electronic protection, especially in the event of current peaks caused by the rapidly changing needs of machine tool loads.



E-T-A

Worldwide Service Network



Europe

- Austria
- Belgium
- Bosnia-Herzegovina
- Bulgaria
- Croatia
- Czech Republic
- Denmark
- Finland
- France
- Germany
- Hungary
- Ireland
- Italy
- Luxembourg
- Macedonia
- Montenegro
- Netherlands
- Norway
- Poland
- Portugal
- Russia
- Serbia
- Slovakian Republic
- Slovenia
- Spain
- Sweden
- Switzerland
- Turkey
- United Kingdom

America

- Argentina
- Brazil
- Canada
- Chile
- Mexico
- USA

Asia

- Brunei
- China
- Hong Kong
- India
- Indonesia
- Japan
- Korea
- Malaysia
- Philippines
- Singapore
- Taiwan
- Thailand

Africa

- South Africa
- Tunisia

Oceania

- Australia
- New Zealand



ENGINEERING TECHNOLOGY

E-T-A Elektrotechnische Apparate GmbH
Industriestraße 2-8 · 90518 ALTDORF
GERMANY

Phone: +49 9187 10-0 · Fax: +49 9187 10-397
E-Mail: info@e-t-a.de · www.e-t-a.com/e